



70 x 42 h4

Lavabo in ceramica da incasso con troppo pieno e quattro lati smaltati. Piletta esclusa.

Fitted ceramic washbasin with overflow and four enamelled sides. Drain not included.

Colorazioni/Colours



Codice/Code

Lavabo Washbasin		SOL18 [] A
Installazione Installation		Incasso Fitted
Troppo pieno Overflow		Con troppo pieno With overflow
Piletta Drain		Up & Down Ø 7,2 cm
Smaltatura Enamelled		4 Lati 4 Sides
Dimensioni Dimensions		70 x 42 x 4h cm
Peso Weight		12,40 kg
Capienza vasca Tank capacity		10,00 Lt
Pallet		100 x 120 x 120h 20 pz. 100 x 120 x 220h 26 pz. 80 x 120 x 180h 17 pz.

Smaltatura Enamelled		Lato inferiore Bottom
		Senza foro No tap Hole
		1 Monoforo 1 Tap Hole
		3 Fori 3 Tap Holes

Raccomandata/Recommended

Codice/Code : PI2UC [] A
Piletta Up & Down in abs cromato con tappo in ceramica standard Ø 7,2 cm.
Chromed abs Up & Down drain with standard ceramic plug Ø 7,2 cm.

Accessori/Accessories
Codice/Code : PI2UACRA
Piletta Up & Down in abs cromato con tappo cromato Ø 7,2 cm.
Chromed abs Up & Down drain with chromed plug Ø 7,2 cm.

Codice/Code : S11TOCRA
Sifone tondo in ottone cromato per lavabo
Round siphon in chrome-plated brass for washbasin

CE EN 14688 - CL15

Dima di taglio
Template



www.valdama.it

Lavabo
Washbasin

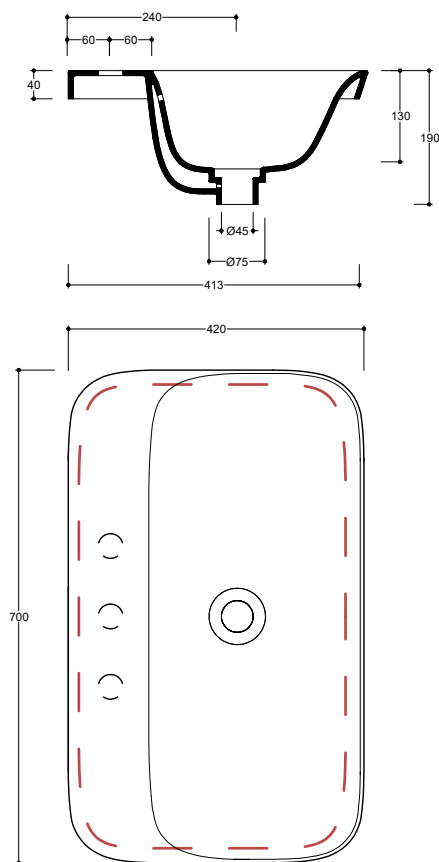

Incasso
Fitted

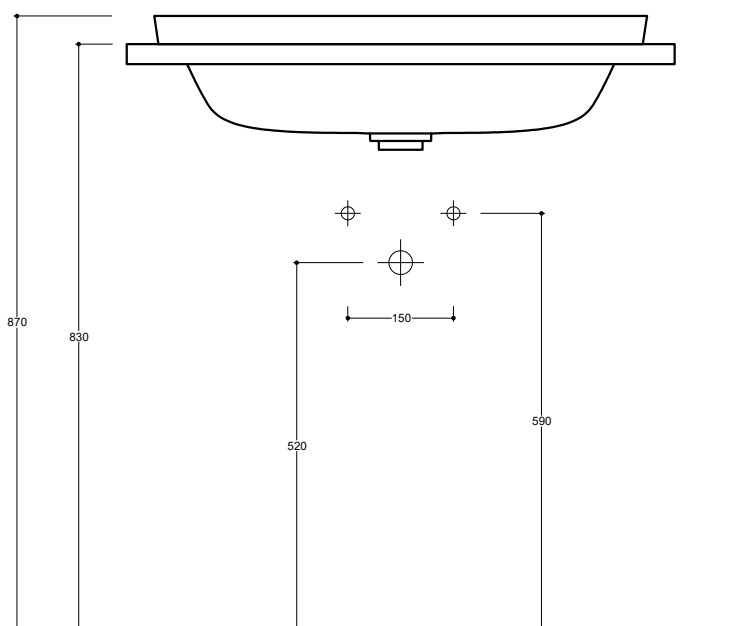

■ Dima di taglio

NB Le misure indicate possono subire una variazione dello 0,8 % circa, dovuta ad un'usura degli stampi o a piccole variazioni delle caratteristiche tecniche relative alle materie prime che compongono l'impasto.
NB Dimensions shown are subject to a variation of about 0,8 % , due to wear of molds or because of small changes in the technical specification of the raw materials of the dough.

ATTENZIONE le quote di installazione si riferiscono ad un impianto standard, sono generiche ed indicative. Si consiglia di adattare le quote in base alle esigenze del cliente.
ATTENTION the installation sheets refer to a standard system, they are generic and indicative. We recommend adapting the dimensions according to customer needs.

SETTEMBRE 2019