

CAMEO design Prospero Rasulo

valdama



90 x 50 x h14

Lavabo in ceramica da appoggio e sospeso con troppo pieno nascosto. Piletta esclusa.

Countertop and Wall-Hung ceramic washbasin with hidden overflow. Drain not included.

Colorazioni/Colours



Lavabo Washbasin		Codice/Code CML07 [] A
Installazione Installation	Appoggio Countertop	
	Sospeso Wall - hung	
Troppo pieno Overflow	Troppo pieno nascosto With hidden overflow	
Piletta Drain	Up & Down \varnothing 8 cm Up & Down \varnothing 8 cm	
Dimensioni Dimensions	90 x 50 x 14h cm	
Peso Weight	25,50 kg	
Capienza vasca Tank capacity	11,00 Lt	
Pallet	100 x 120 x 120h 10 pz. 100 x 120 x 220h 18 pz. 80 x 120 x 180h 9 pz.	

Fissaggi Hardware	Inclusi Included	
	Senza foro CML07 [] A No tap Hole	
Lavabo Washbasin	1 Monoforo CML07 []/1A 1 Tap Hole	
	3 Fori CML07 []/3A 3 Tap Holes	

Obbligatoria/Compulsory Codice/Code : PI4FC [] A



Piletta Scarico libero in abs cromato con tappo in ceramica quadrato \varnothing 8 cm
Chromed abs Free flow drain with square ceramic plug \varnothing 8 cm

Accessori/Accessories Codice/Code: SI1TOCRA



Sifone tondo in ottone cromato per lavabo
Round siphon in chrome-plated brass for washbasin

CE EN 14688 - CL10

Lavabo
Washbasin

Appoggio / Sospeso
Countertop / Wall-hung

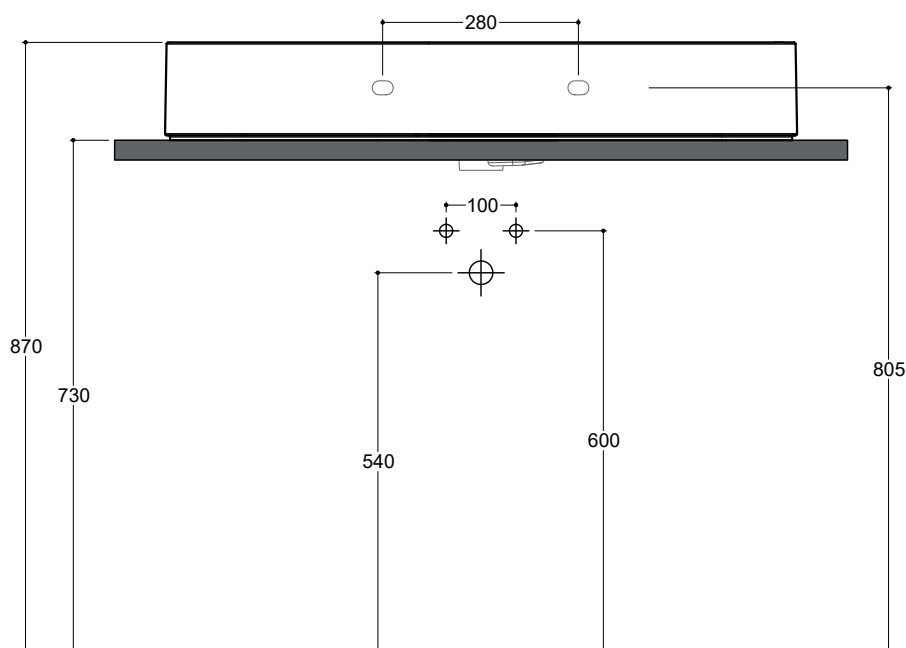
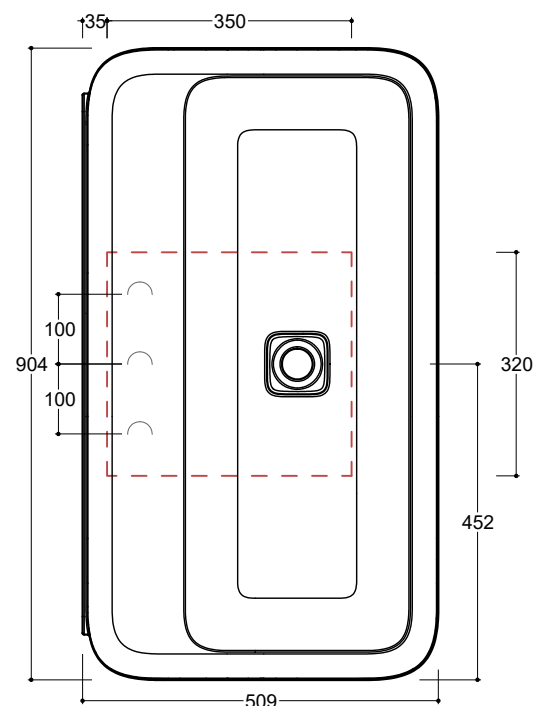
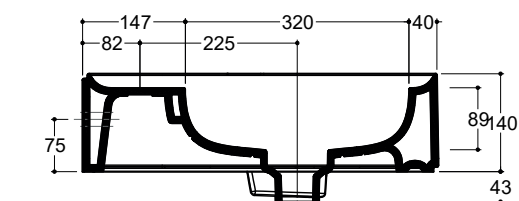

■ Dima di taglio

NB Le misure indicate possono subire una variazione dello 0,8 % circa, dovuta ad un'usura degli stampi o a piccole variazioni delle caratteristiche tecniche relative alle materie prime che compongono l'impasto.
NB Dimensions shown are subject to a variation of about 0,8 %, due to wear of molds or because of small changes in the technical specification of the raw materials of the dough.

ATTENZIONE le quote di installazione si riferiscono ad un impianto standard, sono generiche ed indicative. Si consiglia di adattare le quote in base alle esigenze del cliente.
ATTENTION the installation sheets refer to a standard system, they are generic and indicative. We recommend adapting the dimensions according to customer needs.

LUGLIO 2019